

## Automatic Self-Test Push-in Modular Emergency Module for LED Luminaires (ATS type S)

Please read these instructions thoroughly before use and retain for future reference.

- The emergency module is only suitable for use in Kosnic LED battens, LED low bay where specified on the luminaire datasheet.
- These instructions are generalised for a range of Kosnic luminaire. Please refer to luminaire installation for more details.
- The emergency module is classified as **ATS type S**. This is a stand-alone, self-contained emergency module with localised automatic testing and reporting facilities requiring manual inspection to record the results.
- The emergency module will perform an automatic weekly functional test and an annual full duration test at a random time during a 24-hour period, reporting any faults found with the battery or load.

### Safety Information

- Installation must be carried out in accordance with national building and wiring regulations.
- If you are in any doubt about installing this product, please consult a qualified electrician.
- Before commencing installation or maintenance, turn off and isolate the circuit to be worked on by removing the fuse or switching the circuit breaker off at the distribution board.
- This product is suitable for connection to a 220-240Vac 50/60Hz supply.
- This product is an **IP20 built-in** driver relying on the enclosure for protection.
- Do not use the emergency module if the cable is damaged.
- The emergency module is not suitable for use on a battery supply with a trickle or intermittent re-charging circuit.
- The emergency module is not protected against supply voltage polarity reversal.
- Insulation between the emergency module supply and battery circuit is double insulation.
- The recharging device will recharge the battery normally after removal of a battery short-circuit
- When cutting holes, drilling or screwing take care not to damage existing wiring or pipework.

### General Installation Information

- Follow the luminaire instructions to access the correct installation area inside the luminaire.
- The diagram below shows a typical installation. Specific details may vary from one compatible batten model to another.
- The optional emergency module (A) provides power in the event of a cut in the supply and must be wired to the un-switched permanent supply through the un-switched Live terminal (L1).
- Write the commissioning date on the battery label.
- Stick the Maintained or Non-Maintained emergency luminaire label on the luminaire where it can be seen.
- Ensure that all electrical connections are tight with no loose strands.
- Reconnect the supply.
- The battery leaves the factory in a charged state but may take up to 24 hours to fully charge for a 3-hour test. Charge for 5 minutes before performing a functional test to ensure there is some charge in the battery.

### Specifications

<b>Order Code</b>	<b>BEM05/ST</b>
<b>Input Voltage</b>	220-240 Vac 50/60 Hz
<b>Input Current</b>	20 mA
<b>Battery Output Wattage (max)</b>	5W
<b>Output Voltage</b>	30-190 Vdc
<b>Output Current</b>	20-115 mA
<b>Open Circuit Voltage</b>	200 Vdc
<b>Maximum Working Voltage</b>	200 Vdc
<b>Protection</b>	IP20, For built-in installation
<b>Input to Output Protection</b>	Double Insulation
<b>Battery</b>	LiFePO4 BAT20LFP4
<b>Battery Voltage</b>	6.4 V
<b>Battery Capacity</b>	4000 mAh
<b>Battery Charge Voltage</b>	7.2 Vdc
<b>Battery Charge Current</b>	30-250 mA
<b>Battery Discharge Voltage</b>	5.8-7.2 Vdc
<b>Battery Discharge Current</b>	600-700 mA
<b>Charging Time</b>	24 h
<b>Battery Life</b>	4 Years
<b>Emergency Conversion Time</b>	1 s
<b>Emergency Operation Time</b>	>3 h
<b>Test Function</b>	Automatic and Manual
<b>Length x Width x Depth</b>	150 x 36 x 27 mm
<b>Weight</b>	281 g
<b>Maximum Case Temperature</b>	75 °C
<b>Ambient Temperature Range</b>	0 to 45 °C

## Typical Installation Diagram

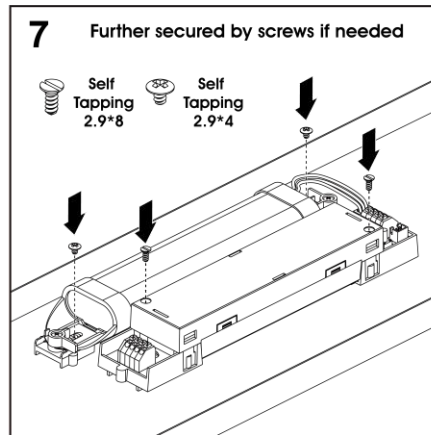
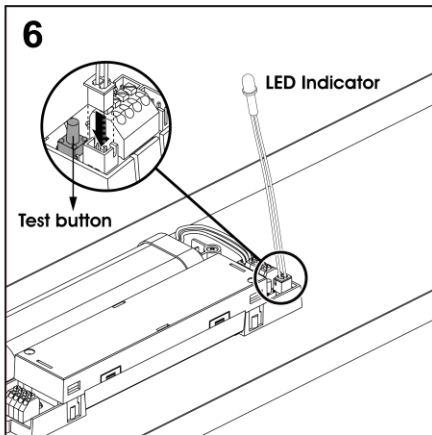
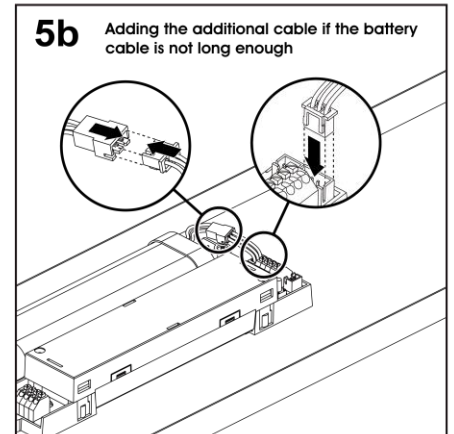
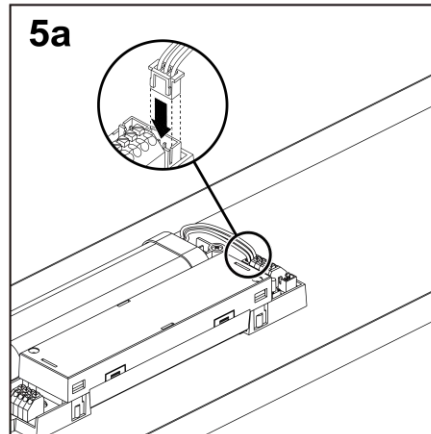
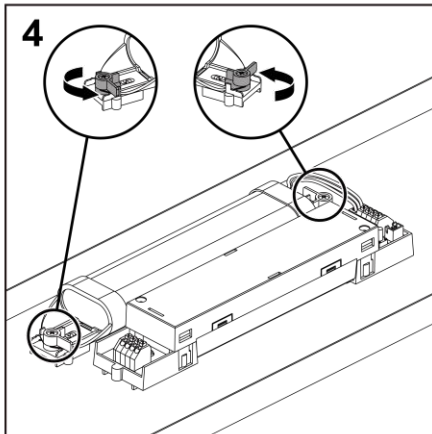
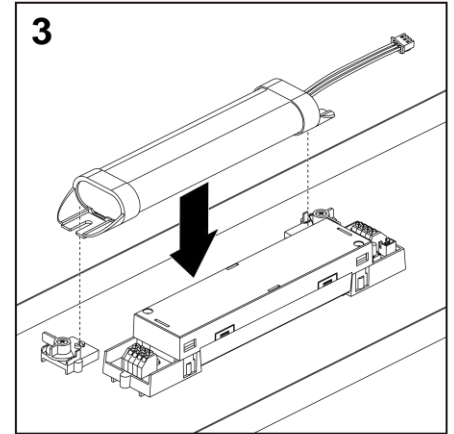
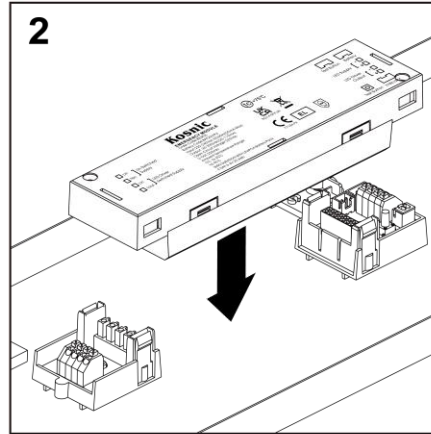
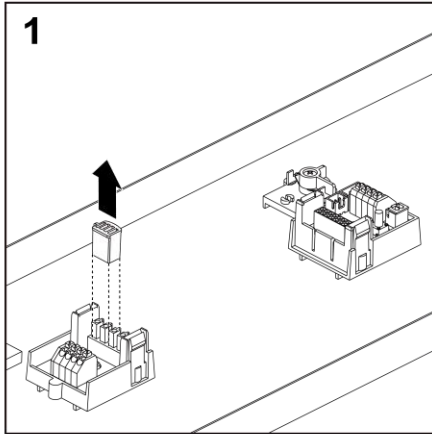

The Waste Electrical & Electronic Equipment Regulations (WEEE) requires that products bearing this symbol must not be disposed of with household waste as they may contain substances harmful to the environment. The Local Authority can provide advice on recycling.

## Automatic Self-Test Emergency Module User Guide







Please read these instructions thoroughly before use and retain for future reference.

If you are in any doubt about using this product, please consult a qualified electrician

### Commissioning

- Commissioning takes place by connecting the battery and then the un-switched supply. The battery must be connected first.
- The green LED will immediately flash 1 x second to indicate that there is a pending duration test.
- A duration test will occur at a random point between 24 hours and 48 hours after commissioning to allow 24 hours for battery charging.
- Any faults found in the duration testing will be reported via the LED indicator, as detailed below.
- Disconnecting the un-switched supply and then the battery resets the emergency module, clears all fault reports and forces a re-commission when the battery and then power supply are reconnected.

### LED Indicator

	<b>Green</b>	= System Healthy		<b>Red</b>	= Battery Charging Fault
	<b>Green Flash 1 x Second</b>	= Duration Test Pending		<b>Red Flash 2 x Second</b>	= Battery Duration Fault
	<b>Green Flash 2 x Second</b>	= Duration Test Running		<b>Red Flash 4 x Second</b>	= Lamp or Luminaire Fault
	<b>Green Flash 4 x Second</b>	= Functional Test Running			

### Duration Testing (3 hours)

- An automatic duration test will occur at a random point between 24 hours and 48 hours after commissioning to allow for battery charging.
- An automatic duration test will occur annually at a random point in the 52<sup>nd</sup> week of each year.
- A duration test will occur at a random point between 0 and 24 hours after pressing the manual test button for 5-10 seconds. Time will be added to allow the battery to charge if the battery has been charging less than 24 hours.
- A duration test may be delayed by other events, such as a power cut that interrupts the test or a lack of charging time, in which case the green LED will flash 1 x second to indicate there is a pending duration test that the emergency module has rescheduled.
- Any faults found in the duration testing will be reported via the LED indicator, as detailed above.
- A functional test will not override any faults reported by a duration test. A full duration test or re-commissioning is required to clear any faults.

### Functional Testing (<2 minutes)

- A short automatic functional test will occur every 7 days.
- A manual functional test will start immediately after pressing the manual test button for 1-2 seconds.
- Any faults found in the functional testing will be reported via the LED indicator, as detailed above.
- A functional test will not override any faults reported by a duration test. A full duration test or re-commissioning is required to clear any faults.

### Manual Testing

- Manual functional test: Press the test button for 1-2 seconds. A manual functional test lasting <2 minutes will start immediately.
- Manual duration test: Press the test button for 5-10 seconds. A manual duration test will occur at a random point between 0 and 24 hours after pressing the test button for 5-10 seconds. Time will be added to allow the battery to charge if the battery has been charging less than 24 hours.

### Pending Duration Tests

- A duration test may be delayed by other events, such as a power cut that interrupts the test or charging period, in which case the green LED will flash to indicate there is a pending duration test that the emergency module has rescheduled until charging is complete.

### Lamp or Luminaire Fault

- Turn off the supply and replace or correct the fault with the lamp or luminaire, and then reconnect the supply.
- Press the test button on the driver for 5-10 seconds. A manual duration test will occur at a random point between 24 and 48 hours later to allow the battery to charge fully.
- If the battery and power have been disconnected the module will re-commission and automatically test the replacement.
- A successful functional test will not override any faults reported by a duration test. A full duration test or re-commissioning is required to clear fault reports.

### Battery Fault

- Turn off the un-switched supply to the emergency module and replace the battery, and then reconnect the supply.
- If the fault was because the battery was not connected, the un-switched supply must still be turned off when connecting the battery to clear the battery fault.
- The emergency module will re-commission and so automatically test the replacement at a random point between 24 and 48 hours after commissioning to allow for battery charging.